

**INSTALLATION GUIDE**

**DOORSF**

**Panic exit breakout system - for mobile and partly fixed leaf  
 for commercial profiles (min. 50 mm)**

D\_MNL0DORRSF\_GB 24-10-2017 - Rev.10

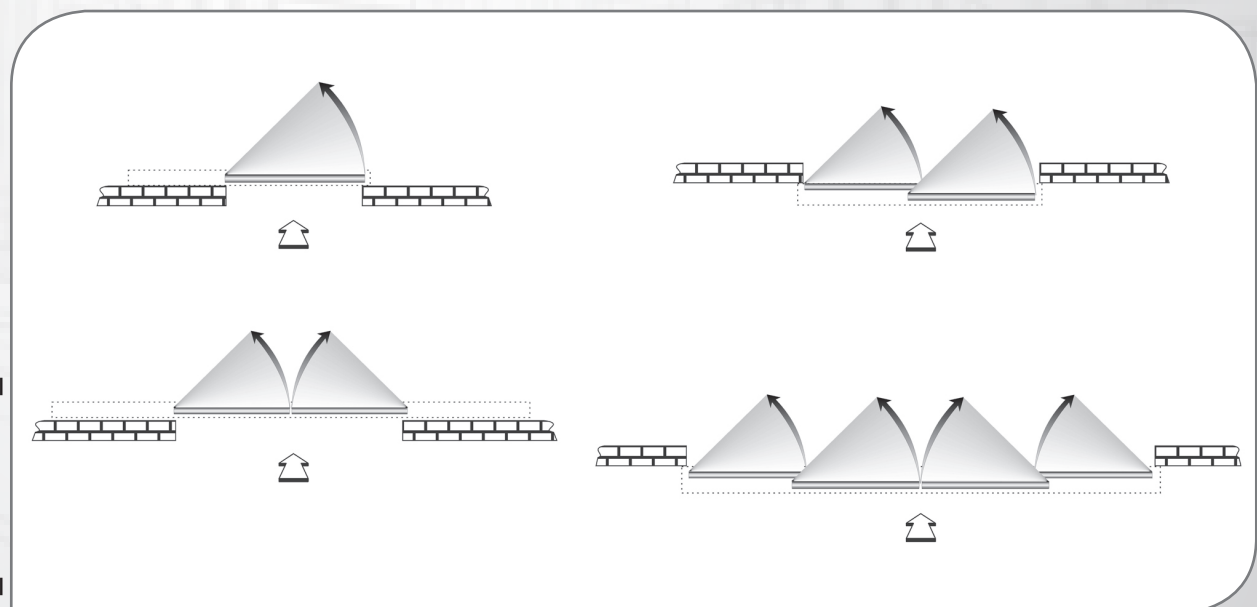

**GB - Translation of Original Instructions**



**MADE IN ITALY**



# Components

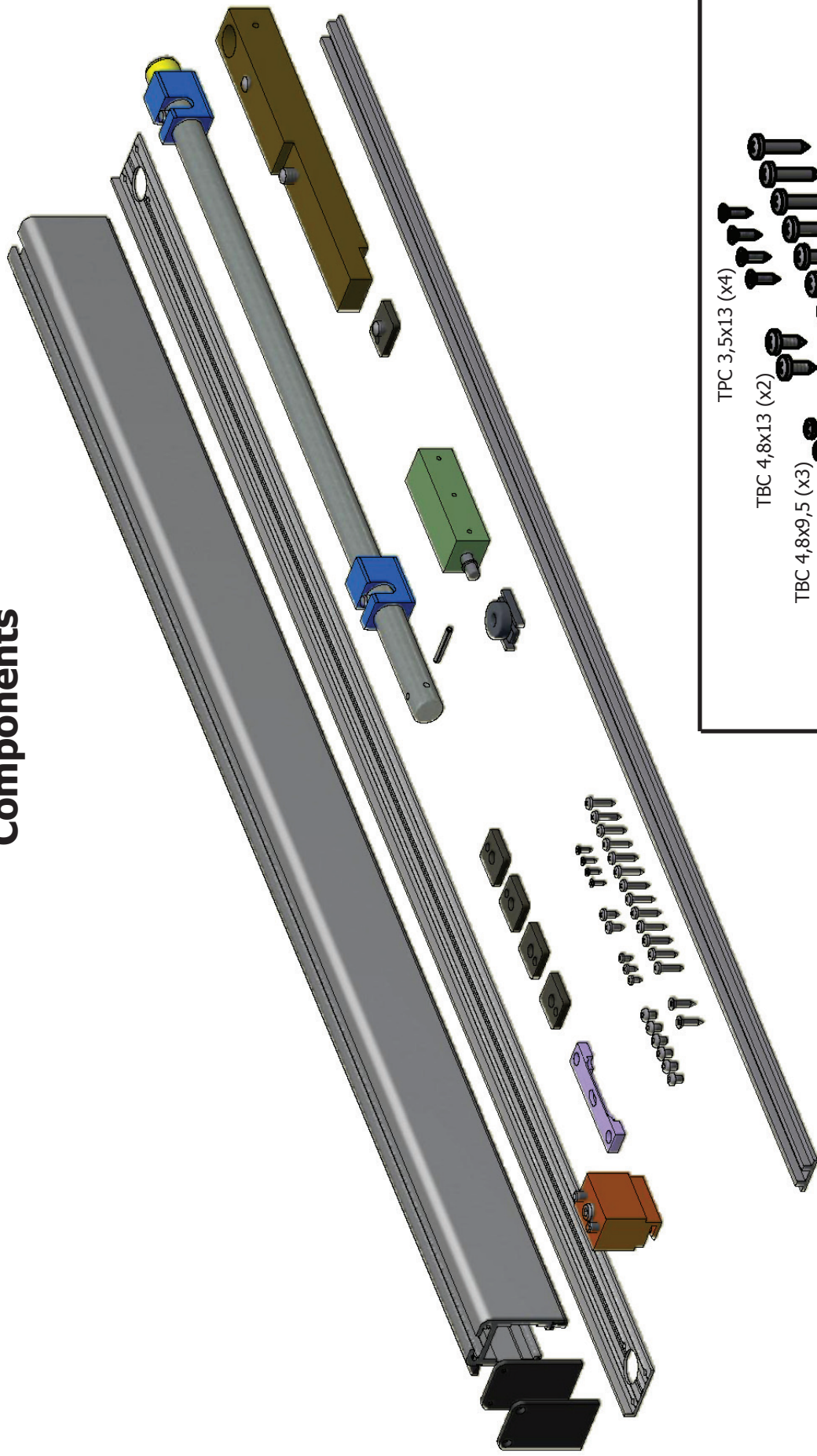

- TPC 3,5x13 (x4)
- TBC 4,8x13 (x2)
- TBC 4,8x9,5 (x3)
- TBEI M6x8 (x6)
- TPC 4,8x22 (x2)
- TBC 4,8x22 (x13)

# Dimensions, Heights and Drilling positions

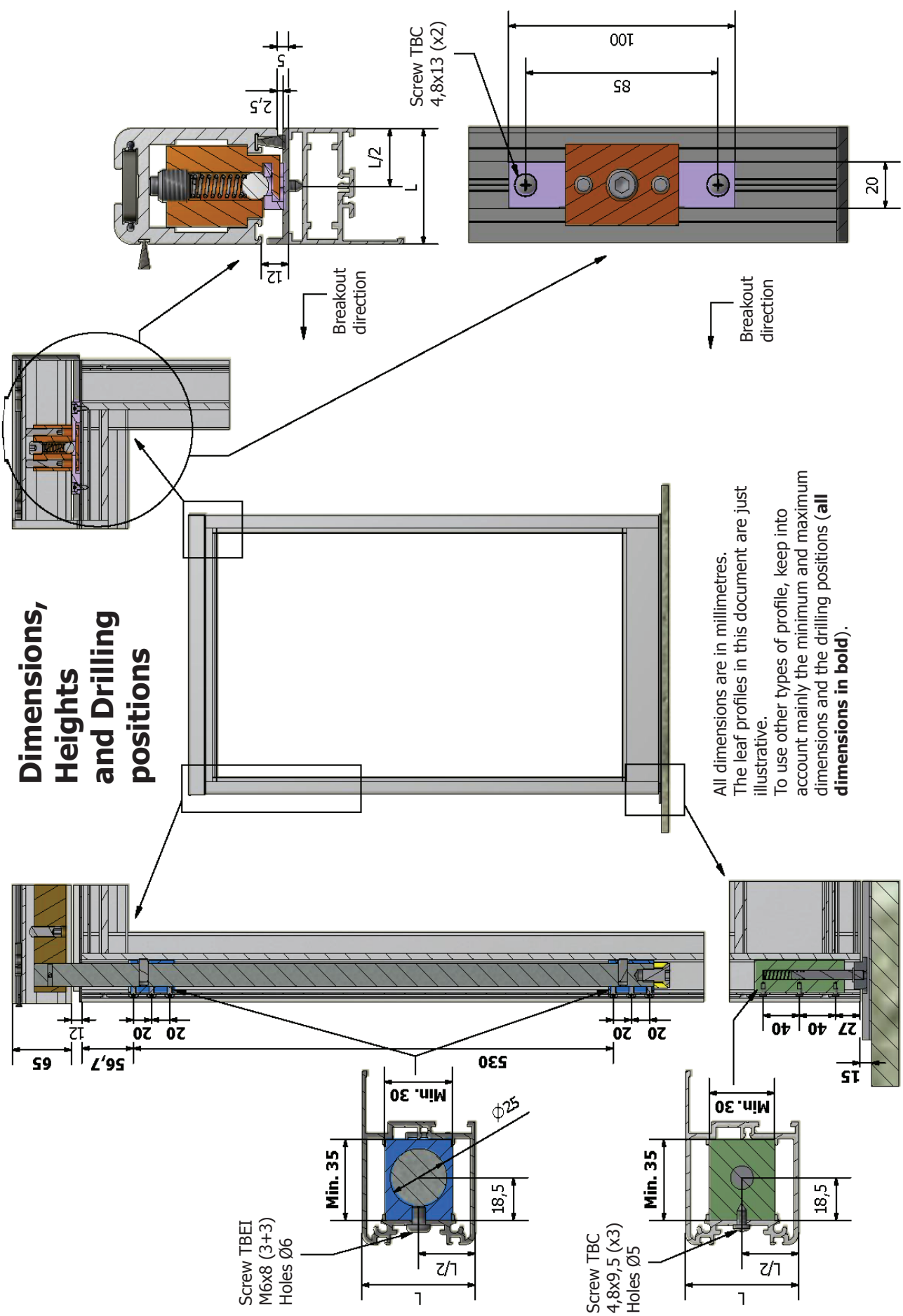

# Assembly of the panic exit system

**1**

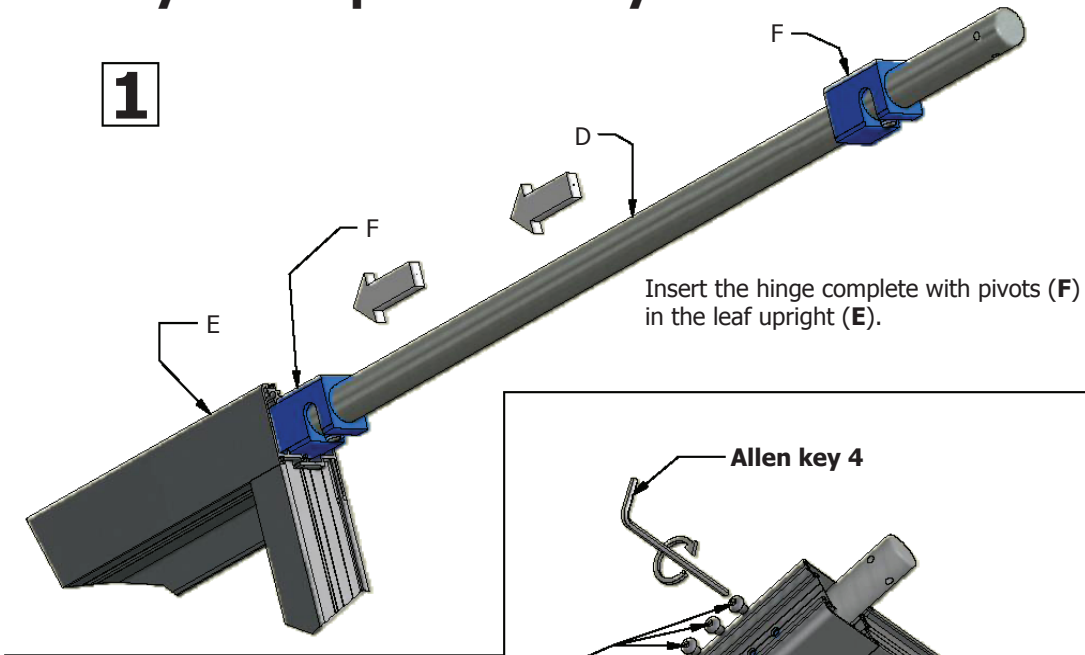

**2**

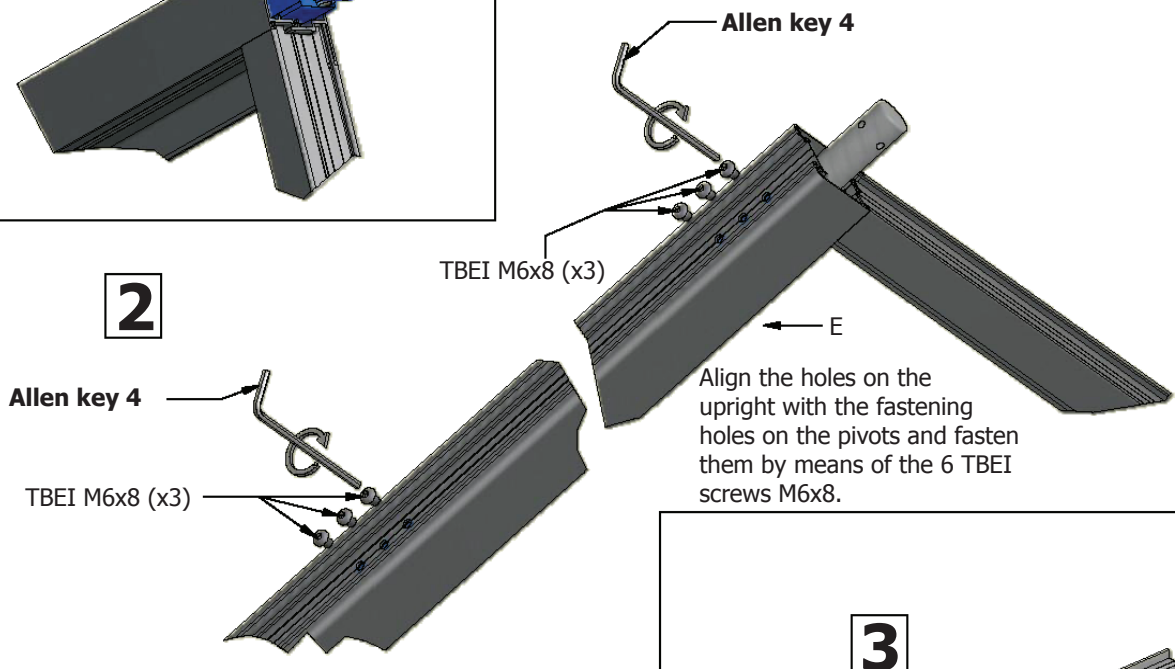

**3**

**IMPORTANT !!**  
 In case of integral breakout, cut 15 mm along the L-shaped profile short part, as shown on figure. This procedure will allow the leaf to rotate freely. The above-mentioned cut will be hidden by overlapping.

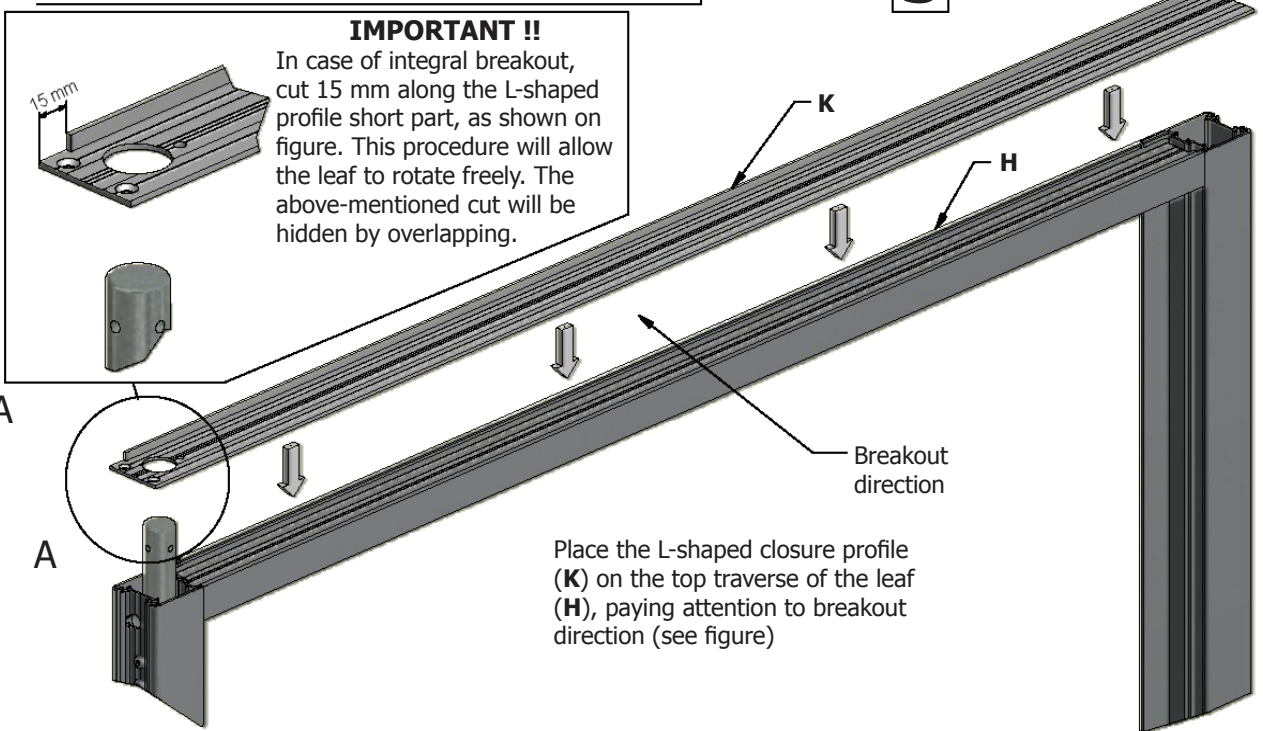



**4**

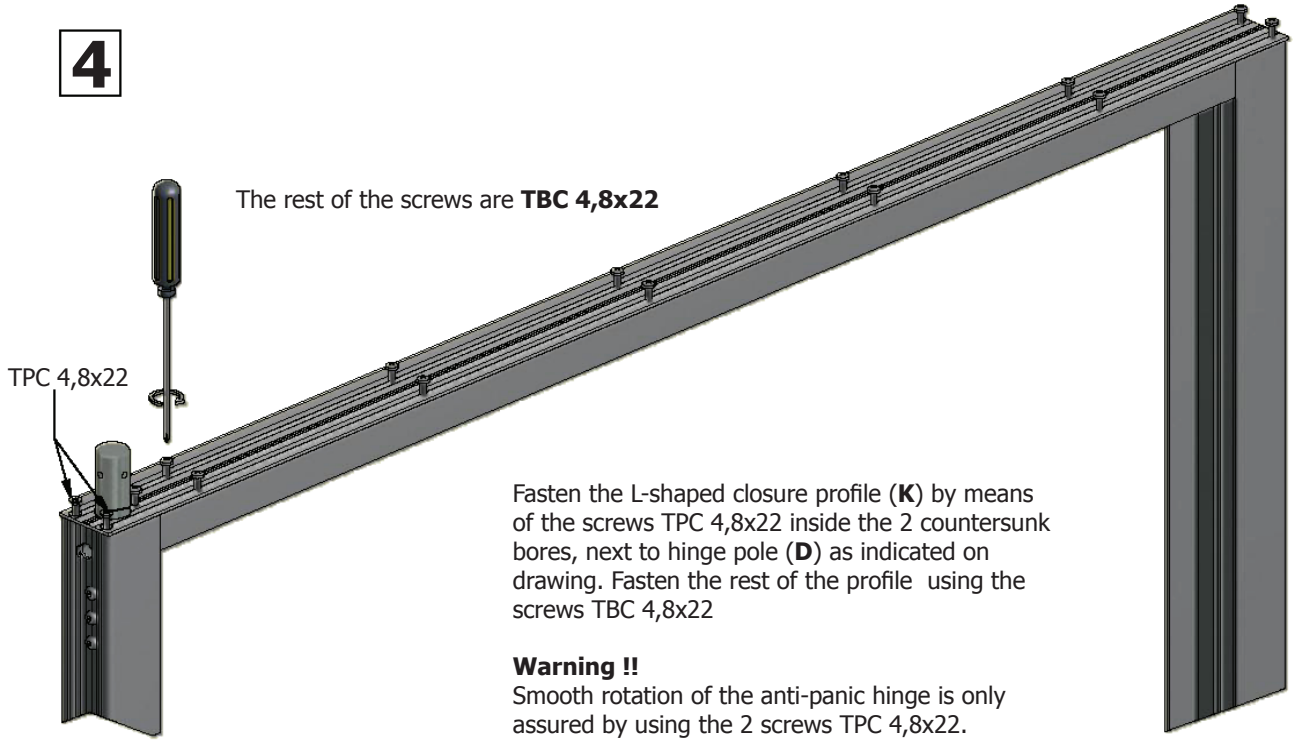

The rest of the screws are **TBC 4,8x22**

TPC 4,8x22

Fasten the L-shaped closure profile (**K**) by means of the screws TPC 4,8x22 inside the 2 countersunk bores, next to hinge pole (**D**) as indicated on drawing. Fasten the rest of the profile using the screws TBC 4,8x22

**Warning !!**  
Smooth rotation of the anti-panic hinge is only assured by using the 2 screws TPC 4,8x22.

**5**

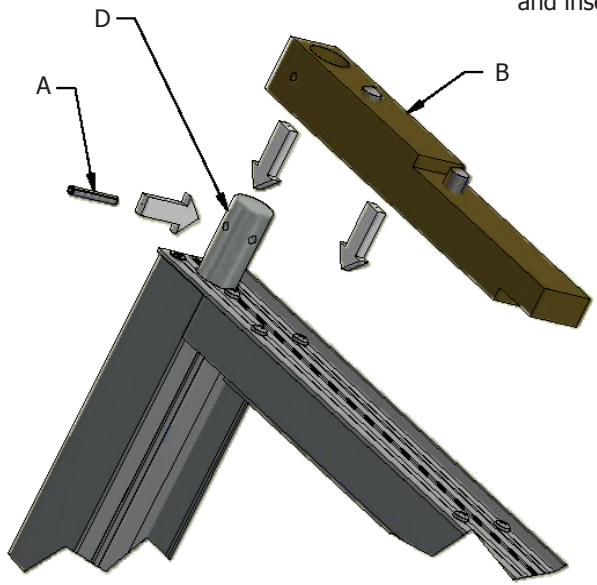

Insert the upper section of the hinge (**B**) into the pole. Upon insertion, make sure that the pole is allowed to rotate 95° around its centre both clockwise and counter-clockwise (see **figure**).  
Align the hole on the pole (**D**) with the hole on the hinge and insert the pin (**A**).

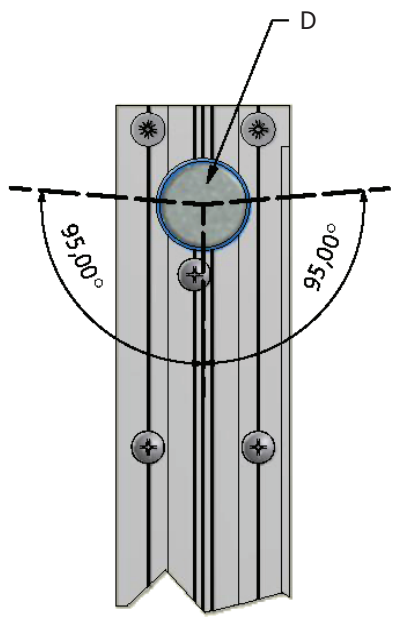

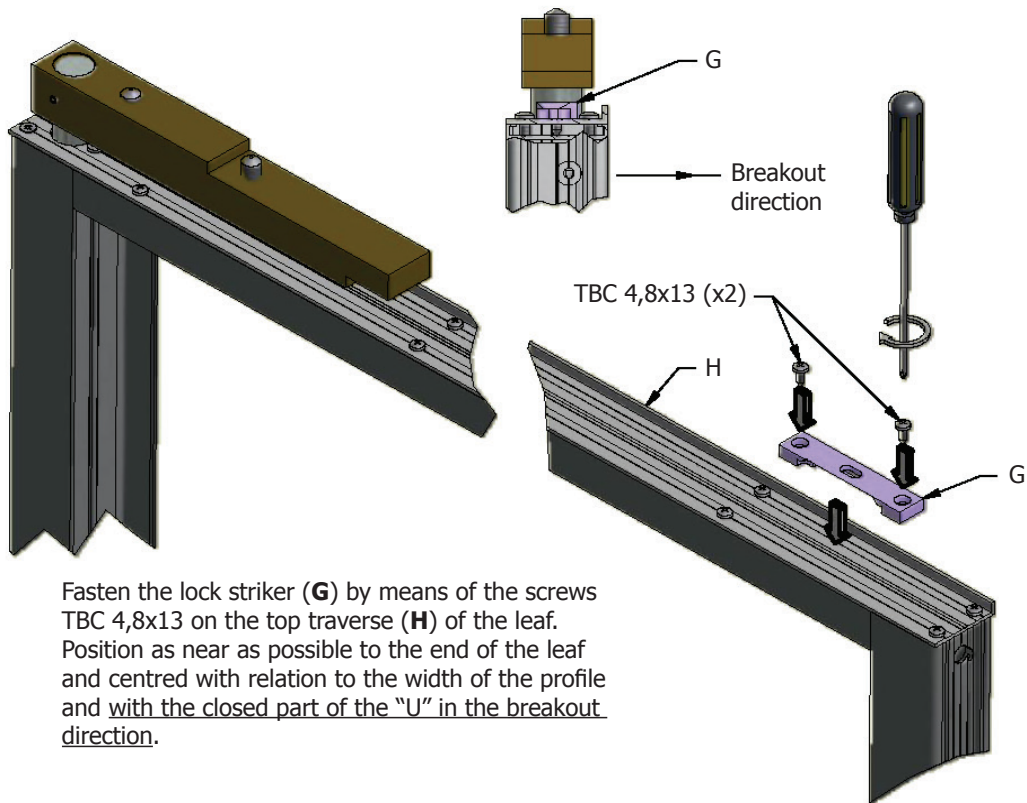

**6**

Fasten the lock striker (**G**) by means of the screws TBC 4,8x13 on the top traverse (**H**) of the leaf. Position as near as possible to the end of the leaf and centred with relation to the width of the profile and with the closed part of the "U" in the breakout direction.

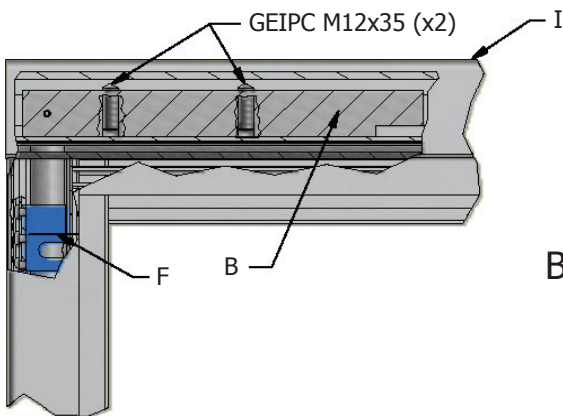

**IMPORTANT !!**

In case of breakout with external operator (mobile leaves only) cut 15 mm along the aluminium short part (**I**), as indicated on drawing. This procedure will allow the leaf to rotate freely. The above-mentioned cut will be hidden by overlapping.

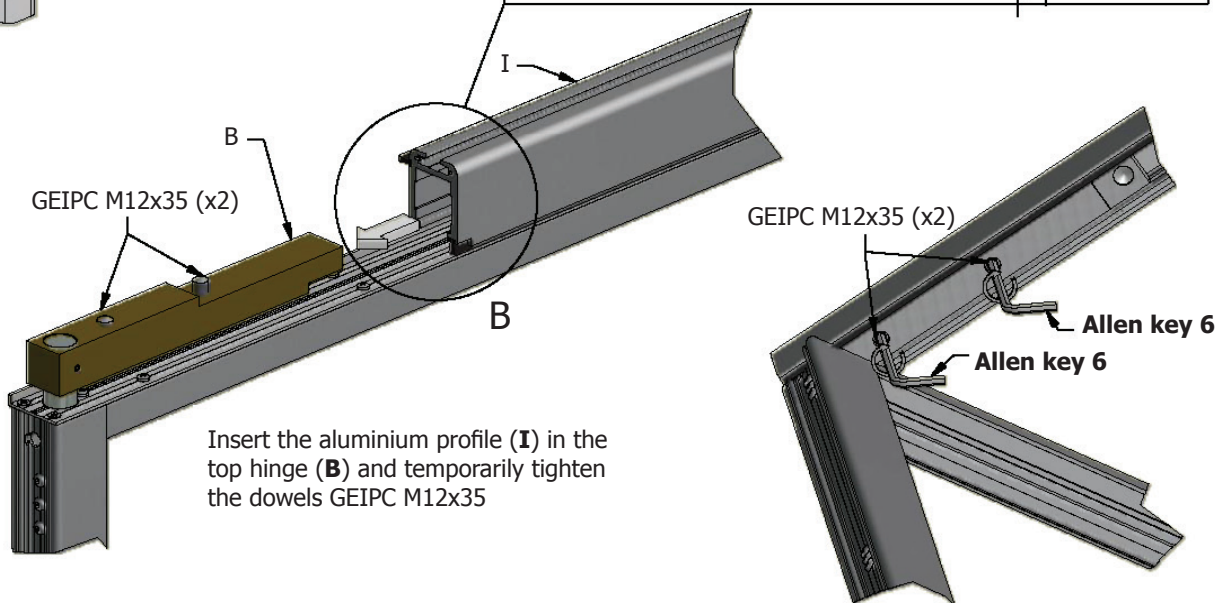
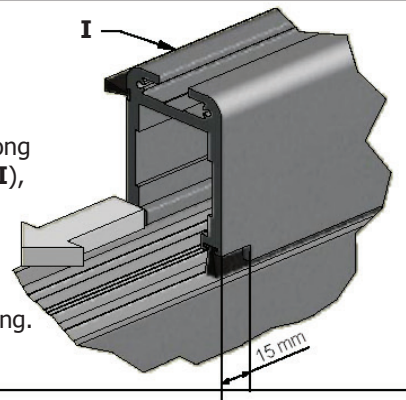

**7**

Insert the aluminium profile (**I**) in the top hinge (**B**) and temporarily tighten the dowels GEIPC M12x35

8

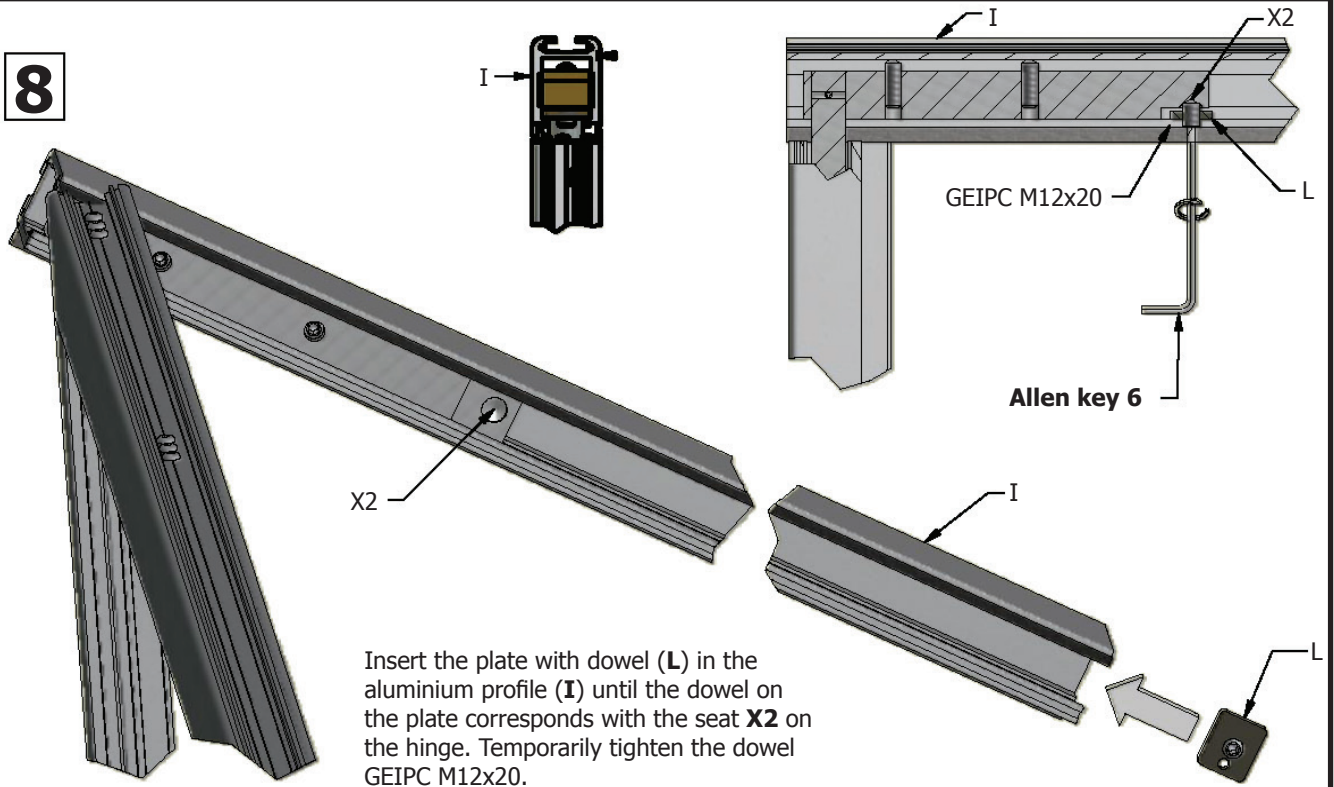

9

Insert the ball block (M) in the aluminium profile (I) until, with leaf closed, it corresponds with the position of the lock striker (G) previously fastened to the upper traverse.  
Tighten the 2 dowels GEIPP M8x40 to fasten it in correct position.

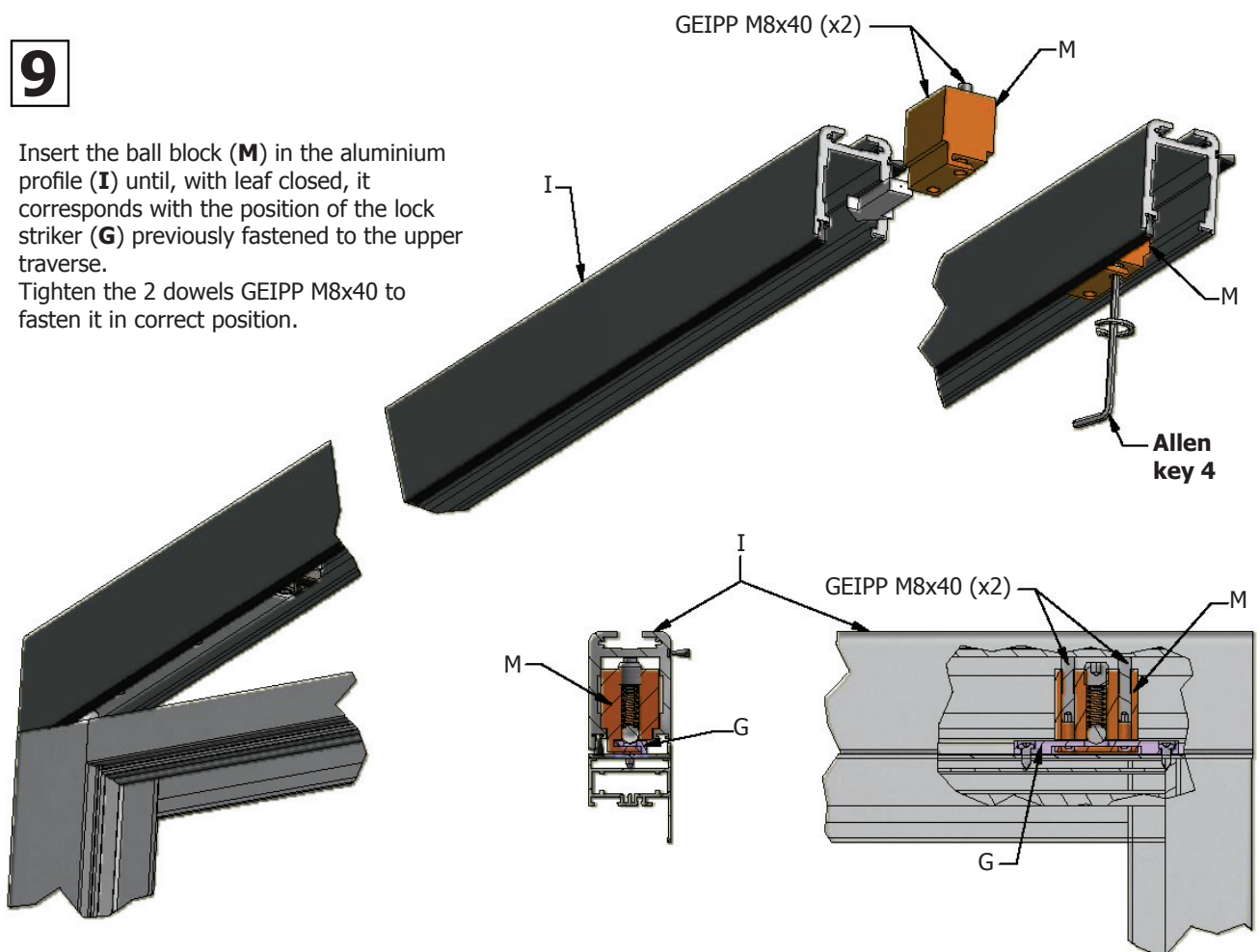

**10**

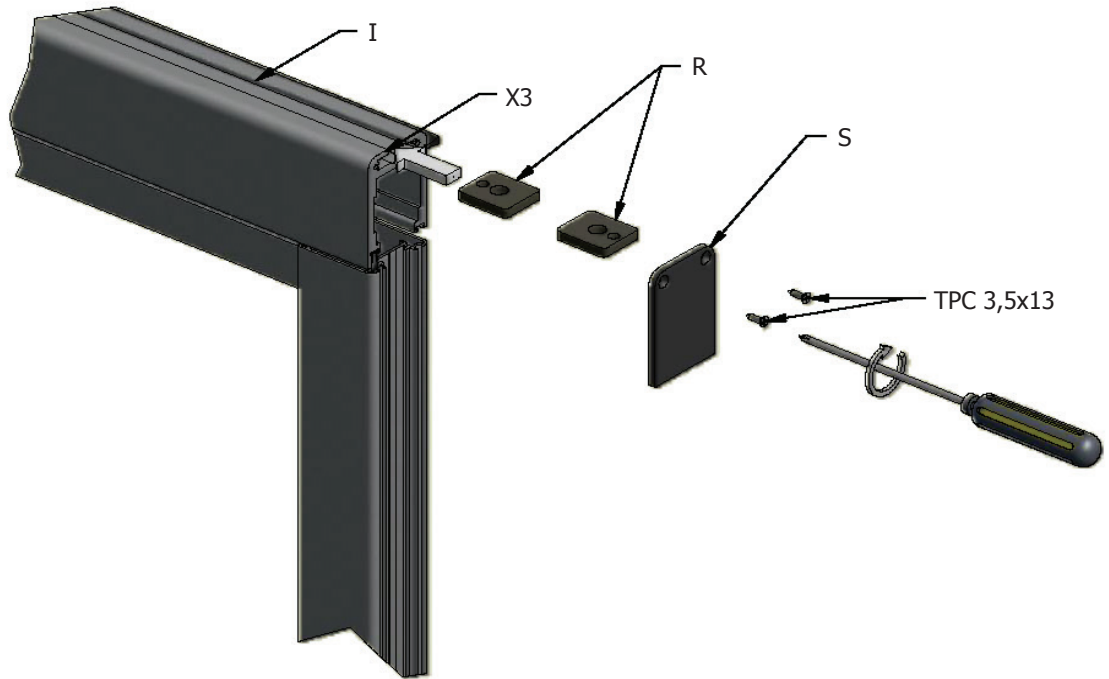

Before closing at its two ends the aluminium profile (**I**), insert from both sides 2 plates (**R**) in the slot (**X3**). Their purpose is to connect the brackets of the carriages located on the automation. Once they have been inserted, close with the rubber caps (**S**) both sides of the aluminium profiles.

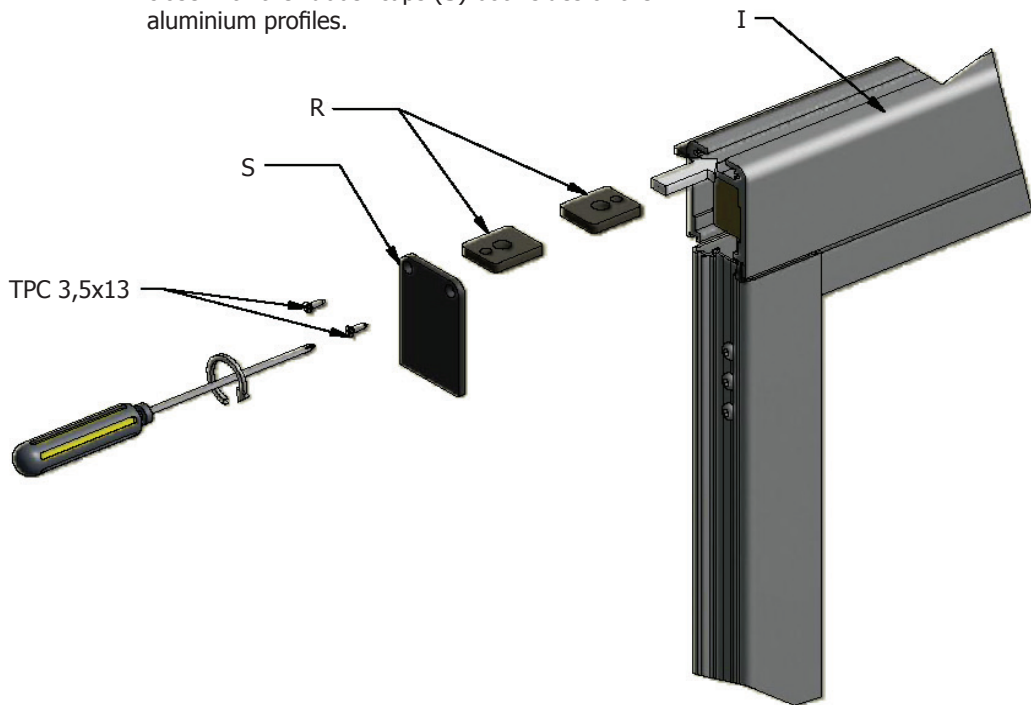



**11**

Thread the runner liner (**N**) in the lower section of the upright (**E**).

! To avoid pin and spring exit from the liner, temporarily tape the pin with the liner.

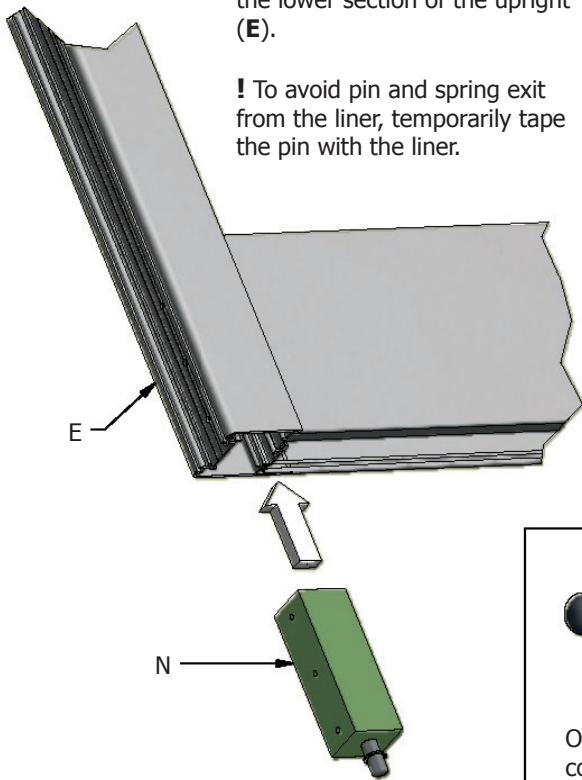
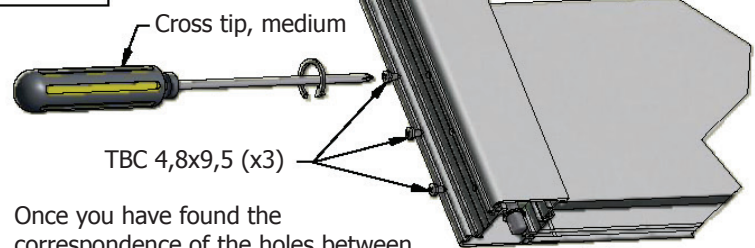
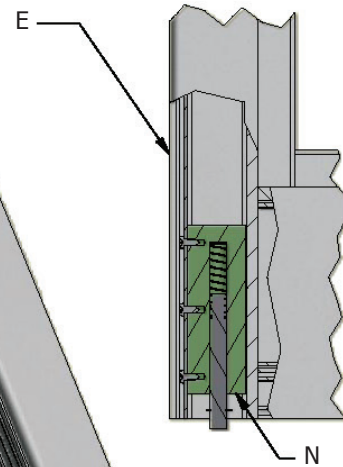
**12**

Once you have found the correspondence of the holes between runner liner (**N**) and upright (**E**), fasten the liner with the screws TBC 4,8x9,5 (x3).

**13**

Fasten the guide to the floor (**P**) and insert the runner (**O**).

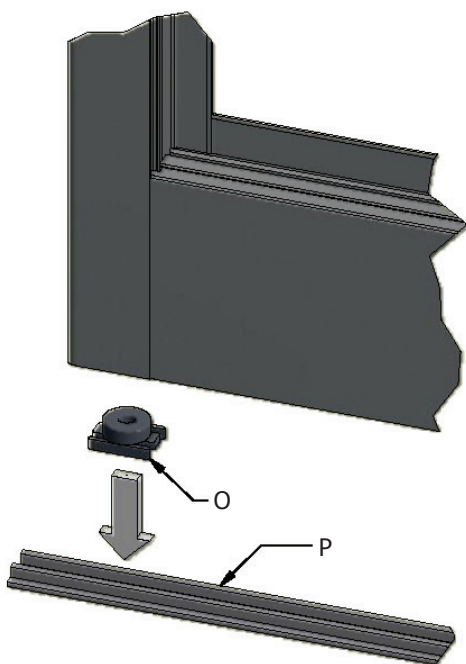
**14**

Position the leaf (**Q**) on the guide (**P**) and insert the pin in the runner (**O**), removing the ribbon previously used to keep in position pin and spring.

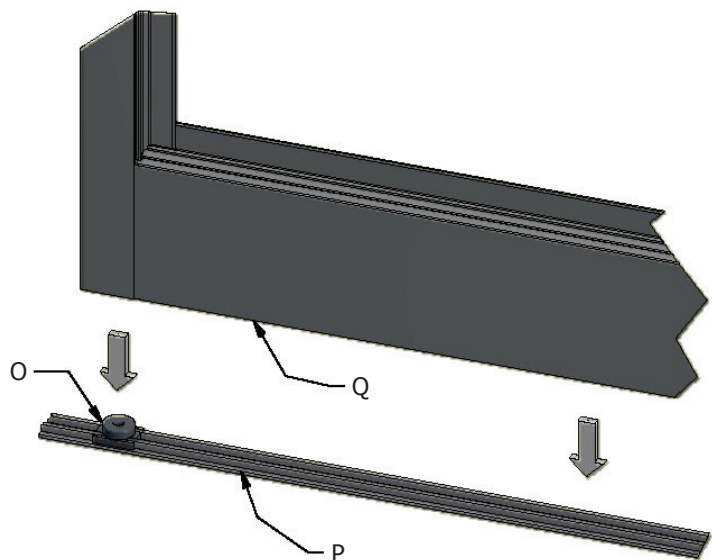



## Adjustment of the leaf weight compensation.

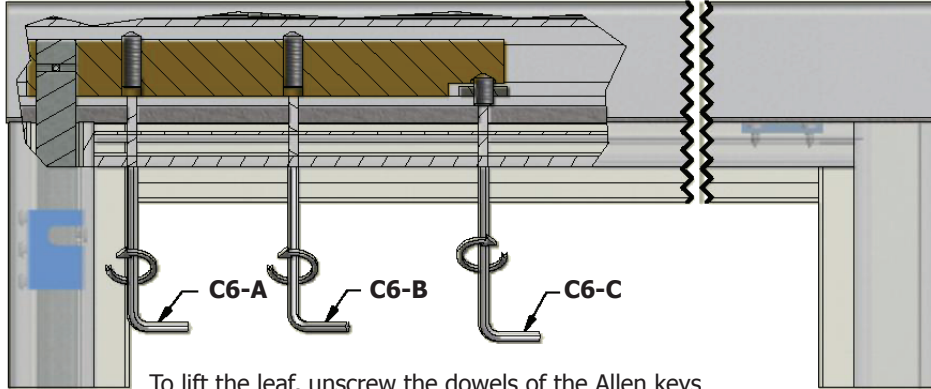

To lift the leaf, unscrew the dowels of the Allen keys **C6-A** and **C6-B** and screw the dowel of the Allen key **C6-C**

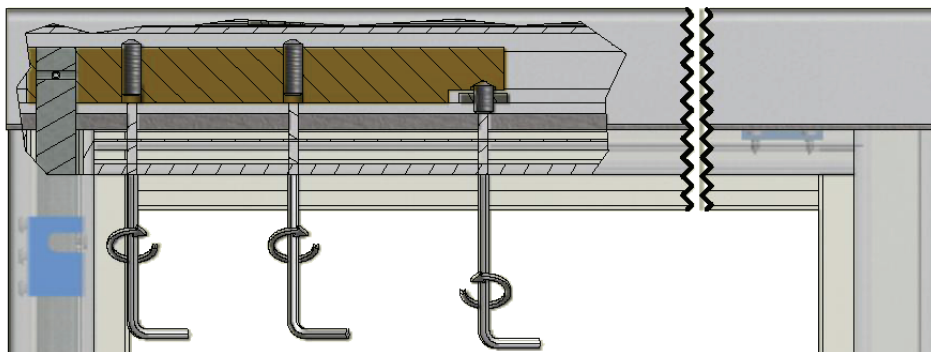
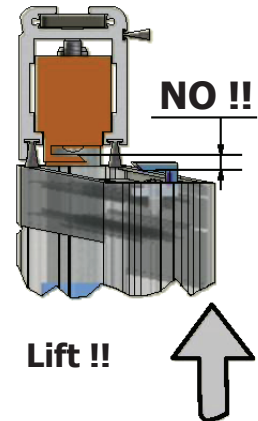

To lower the leaf, unscrew the dowel of the Allen key **C6-C** and screw the dowels of the Allen keys **C6-A** and **C6-B**.

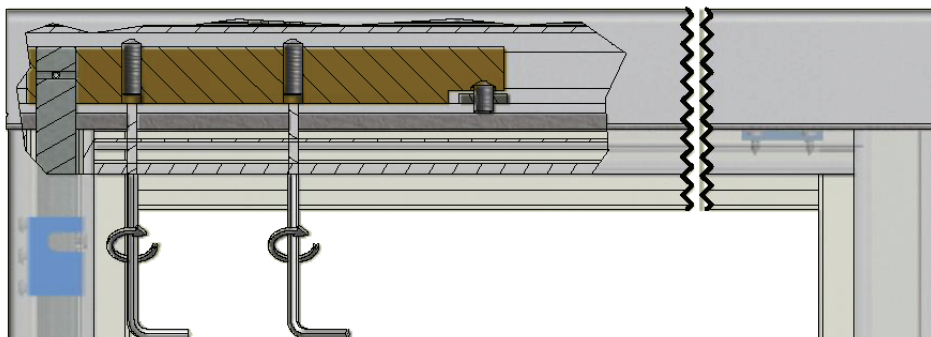
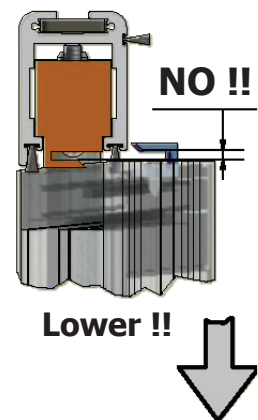

To lock leaf position, fully tighten the dowels of the Allen keys **C6-A** and **C6-B**

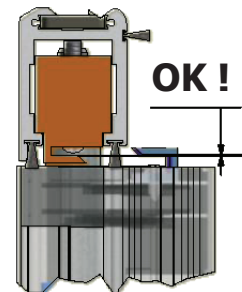

## Adjustment of the mobile leaf spring latch.

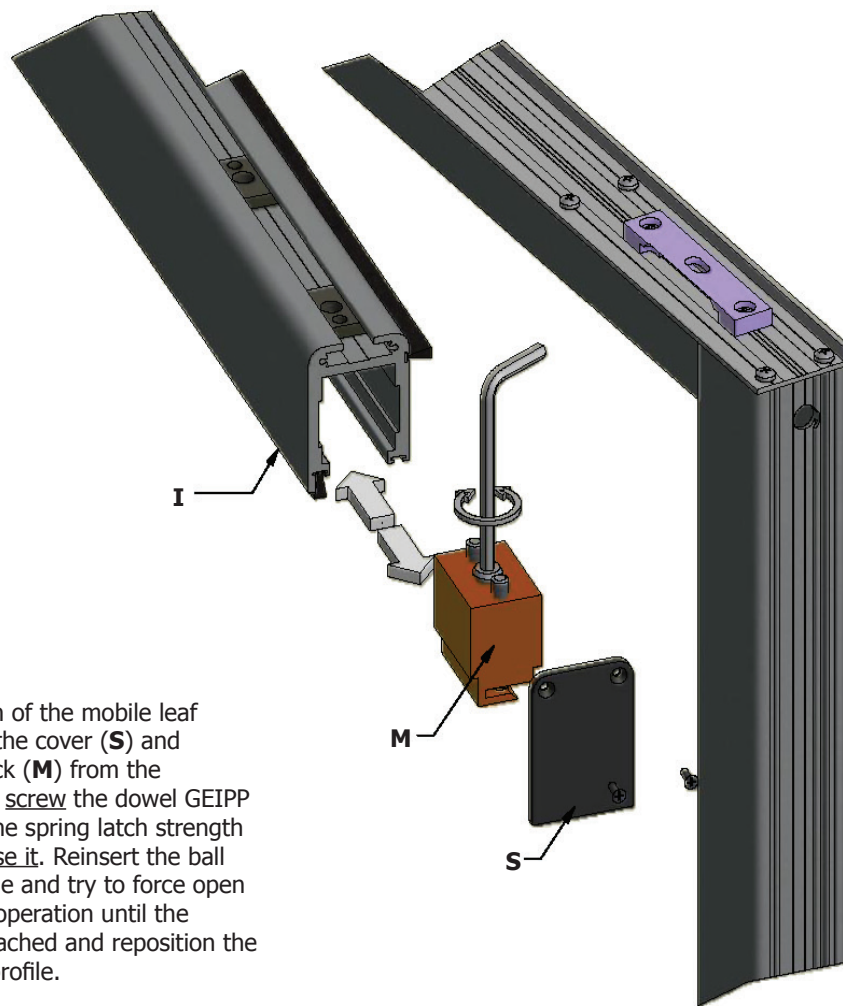

To adjust the strength of the mobile leaf spring latch, remove the cover (**S**) and withdraw the ball block (**M**) from the aluminium profile (**I**), screw the dowel GEIPP M14x14 to increase the spring latch strength or unscrew to decrease it. Reinsert the ball block (**M**) in the profile and try to force open the door. Repeat the operation until the desired strength is reached and reposition the rubber cover on the profile.

## Installation of the partly fixed leaf spring latch.

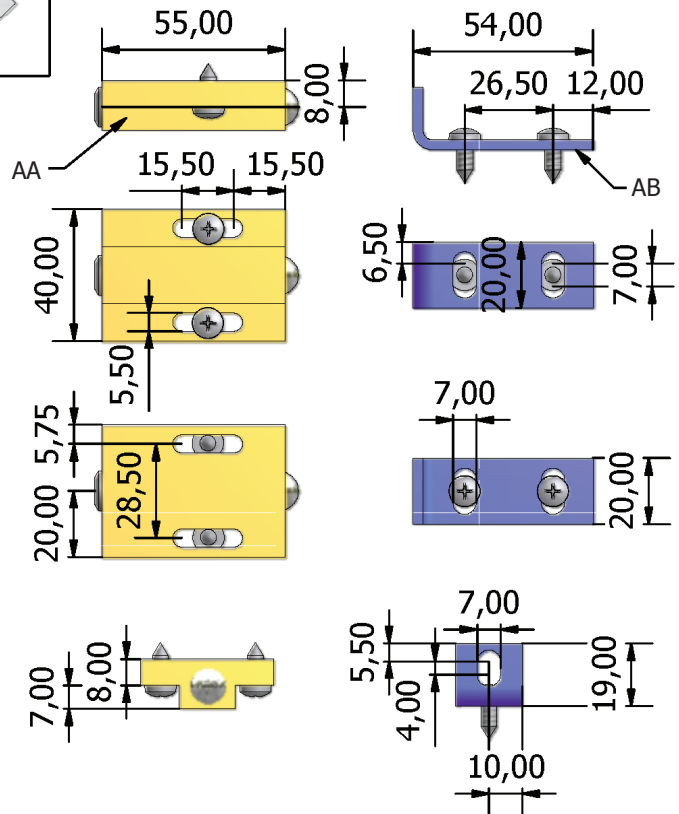
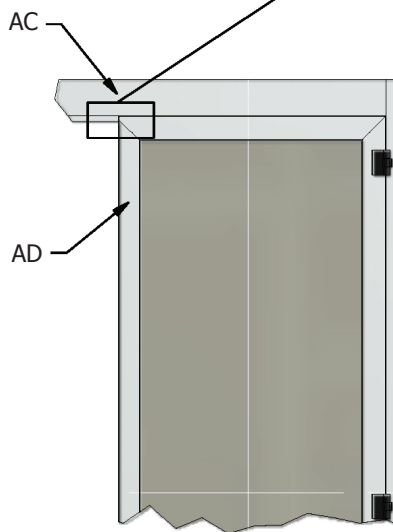
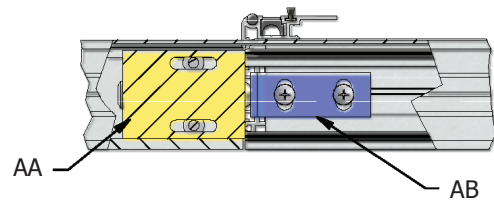
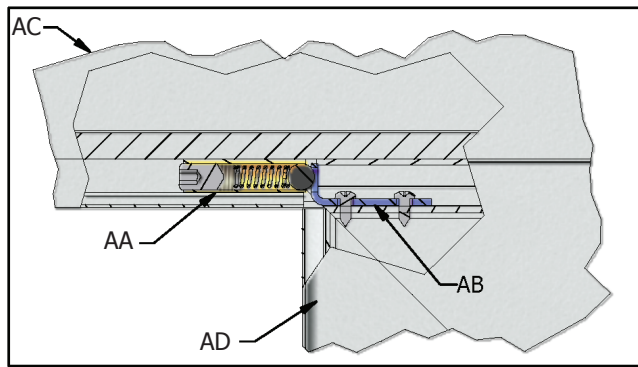

Position the partly fixed leaf spring latch (**AA**) on the wall frame (**AC**) with the part with the ball in correspondence with the end section of the partly fixed leaf. Now fasten the spring latch striker (**AB**) on the end section of the partly fixed leaf (**AD**) and, closing it, check for interferences and verify that the ball is positioned in the striker slot.

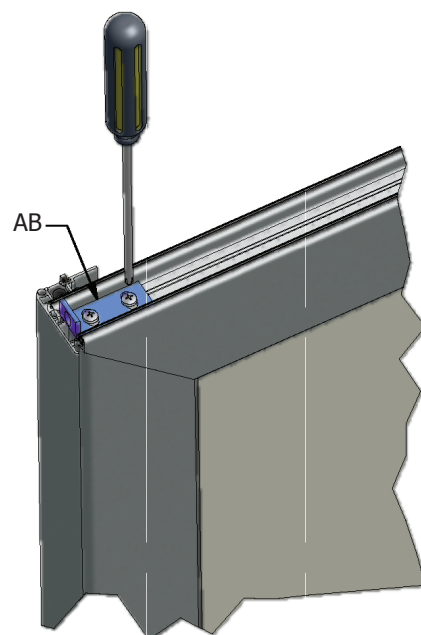
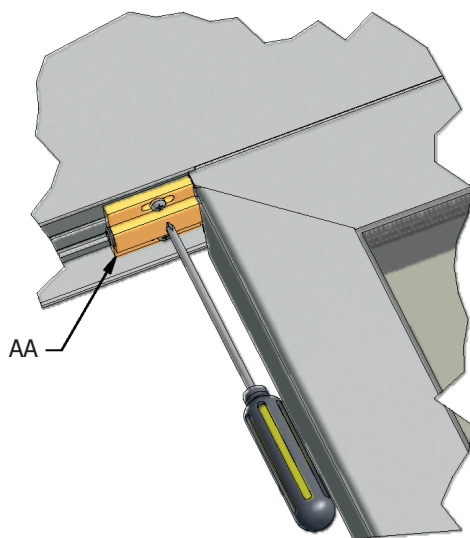

## MOBILE LEAF GLASS SHIMMING

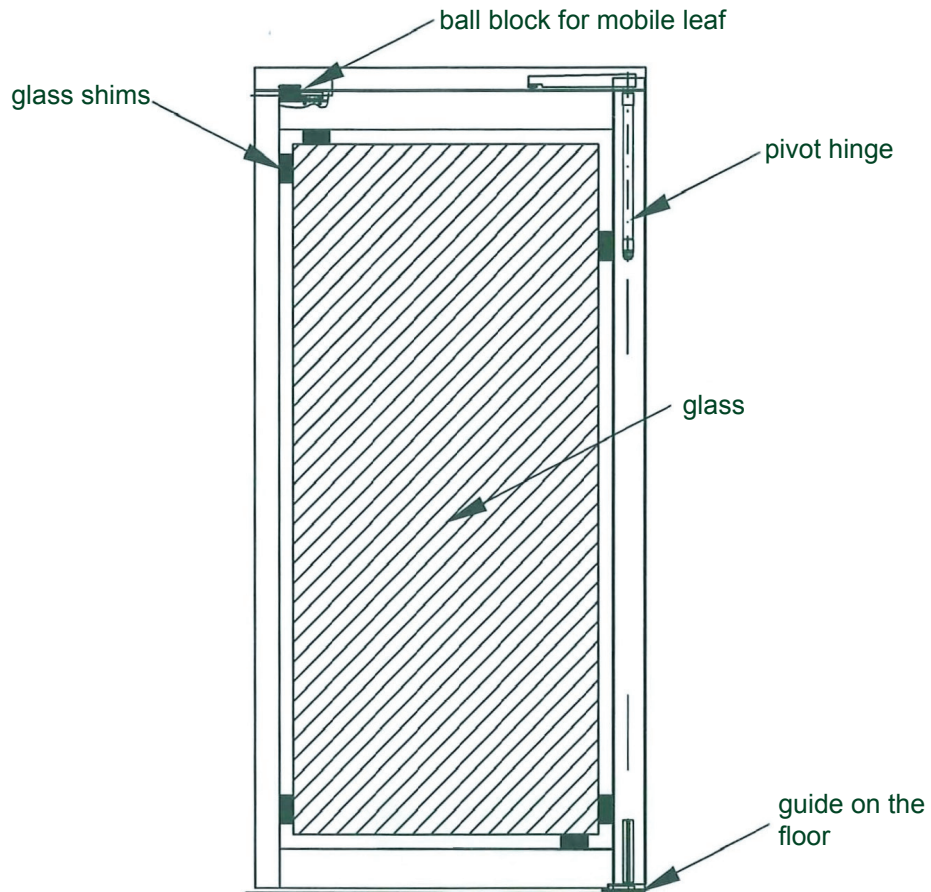

**NB: GLASS SHALL NOT OVERWEIGHT THE LEAF**









Via Enrico Fermi, 43  
36066 Sandrigo (VI) - Italy  
Tel +39 0444 750190  
Fax +39 0444 750376  
info@tauitalia.com  
www.tauitalia.com